



RFI Solutions from KHz to GHz

ABC's of RFI for Hams



Bob Brehm, AK6R
Chief Engineer
Palomar-Engineers.com

Santa Clarita ARC – 1/15/2025
This presentation available on website
Copyright 2013-2025 Palomar Engineers, Inc.

Palomar Engineers Short History

- Founded in 1965 by Jack Althouse, K6NY (aka Kurt Sterba)
- Reorganized in 2013 as RFI Solutions/Antenna company
- **Objective:** Provide products that make radio communication more effective & enjoyable
- **Product Line**
 - Ferrite Core Products
 - Baluns, Ununs, Feedline Chokes & Coax Noise Filters
 - Antenna Systems (OCF, End Fed, Loop, Terminated)
 - RFI Solution Kits for Ham, Commercial, Household
 - Kurt Sterba Books/Downloads
- **Distribution:** Ham Radio Outlet, Direct, eBay
- **Markets:** Consumer, Commercial, and Military

Let's talk about RFI

Are you the **SOURCE** of RFI?

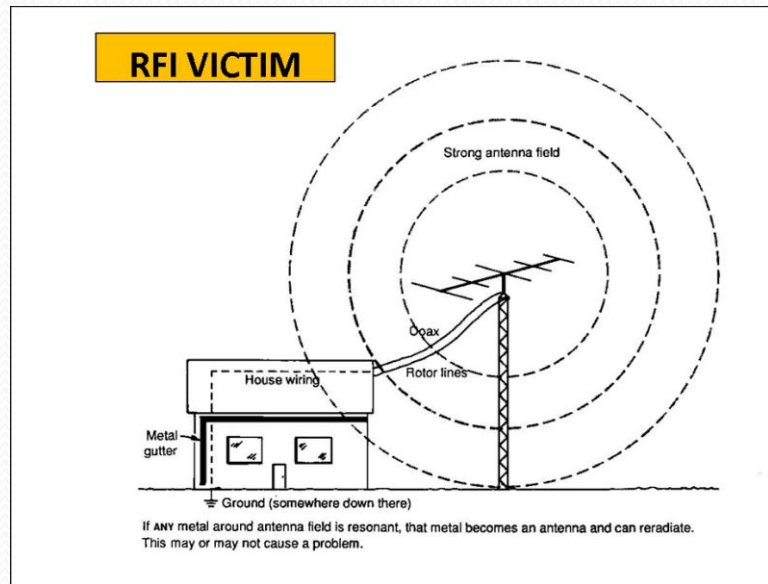

IT'S ALL YOUR FAULT WITH THAT BIG ANTENNA!

Maybe you got an award!



RFI Solutions from KHz to GHz

Worked All Appliances

AWARDED TO

Amateur Radio Station _____

Who has caused persistent Radio Frequency Interference (RFI)
to electronic appliances adjacent to the ham radio station

Awarded this ____ day of _____, 20__

RFI Case Endorsements:



Bob Brehm, AK6R
Chief Engineer



RFI Solutions from KHz to GHz



WORKED ALL NEIGHBORS

AWARDED TO

Amateur Radio Station _____

Who has caused persistent Radio Frequency Interference (RFI) to neighbors adjacent to the radio station

Awarded this ____ day of _____, 20__

RFI Case Endorsements:



Bob Brehm, AK6R
Chief Engineer

Are you a **VICTIM** of local RFI?

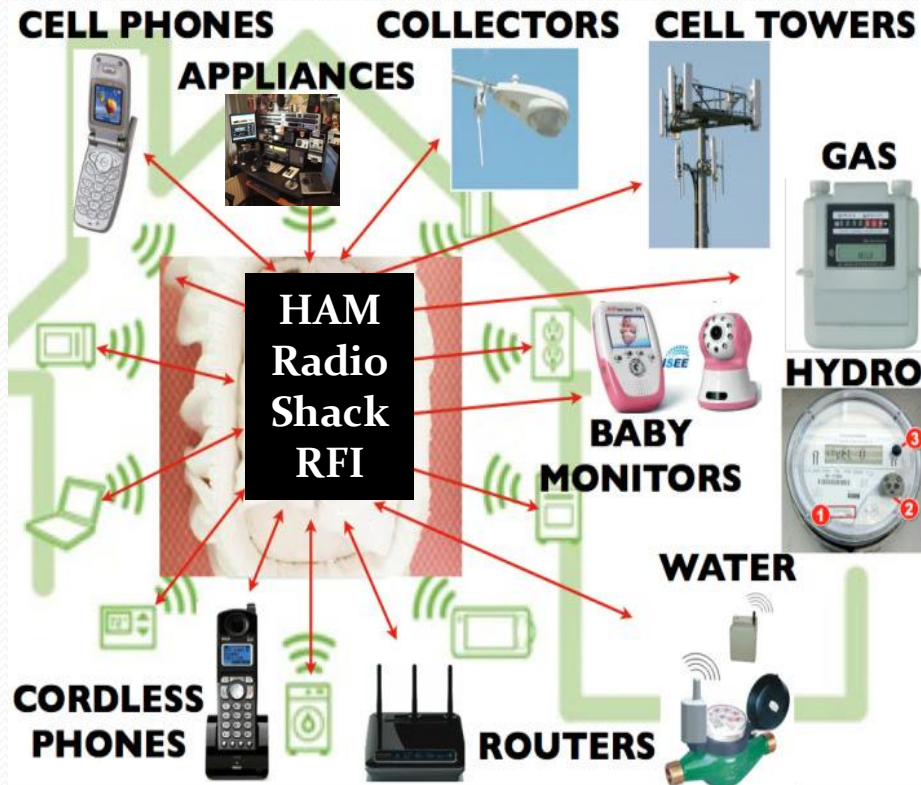

RFI Sources

- Ham Antenna
- Radiating Coax
- Electronic Devices
- Solar Systems
- Grow Lights
- HVAC motor
- Plasma TV
- DSL/Routers
- Switching power Supplies
- Washer/Dryer or other appliances

QRN - High Noise Floor – Weak Signals – NO DX – No fun!

Source or Victim – we can help!

Workshop Objectives

RFI Workshop Objectives



- Learn fundamentals of RFI - identify symptoms, pinpoint causes & apply simple cures
- What's a ferrite filter and how to choose & buy the right ferrite for your RFI issue
- How to use ferrites to solve the #1 RFI problem shared by all hams using coax-fed HF antennas
- How to use ferrites to solve transmitter RFI problems, reduce your receiver noise floor, and keep your neighbor's and spouse happy!
- Understand CONCEPTS with little or NO MATH required

Thinking cap time.....

What is RFI?

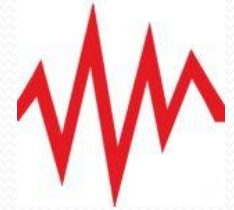

- *A radio frequency (>100 KHz) disturbance that causes an electrical circuit to function improperly*

Common Sources

- Sunspots, Cosmic noise, Lightning, atmospheric static, AC power lines (**no ferrite fix**)
- “Transmitters” - Ham, CB, AM/FM, electronic devices, speed controllers, inverters, switching power supplies, computer electronics, Cable/DSL/Ethernet (**can use filters to fix**)
- Common Victims
 - Any electronic device that malfunctions by acting as an unintended “receiver” of RFI

How do you get RFI?

How RFI is Transferred

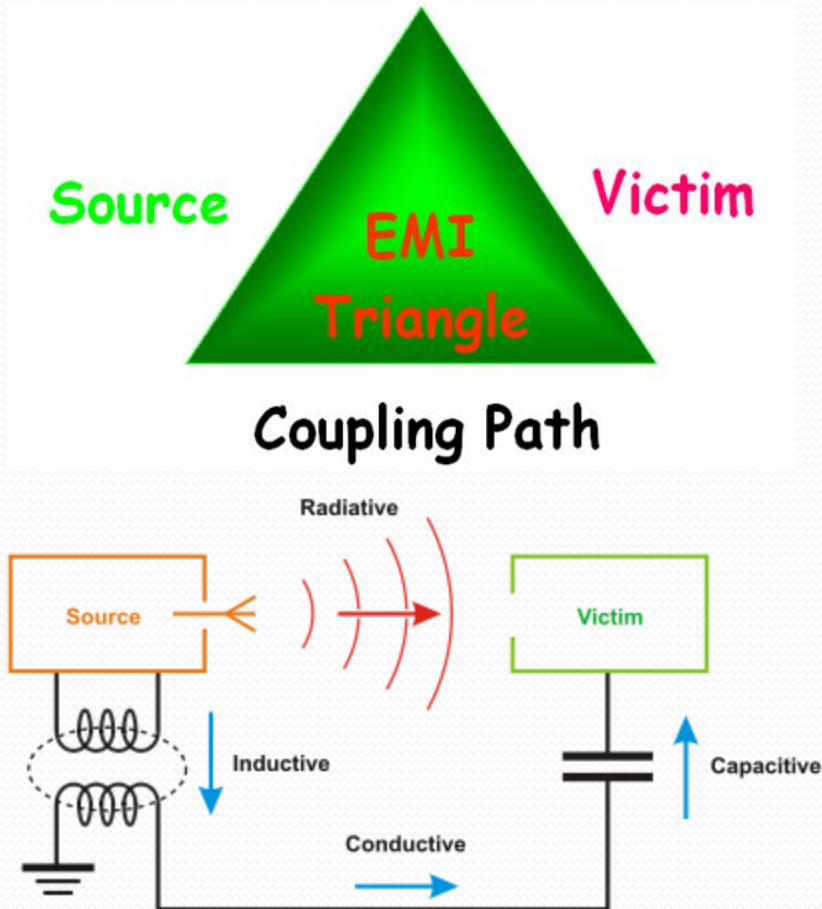

Source (antenna) and **Victim** (antenna) coupled via **Path** (all must be present to have RFI)

Multiple paths are very common:

1. Radiative - air
2. Conductive – wire(s)
3. Inductive - wire
4. Capacitive - wire



How to find the source & path

Typical RFI in your shack/home

- **TX Symptoms** – caused by your transmitter or antenna
 - Hot microphone – RF lip burns, distorted audio
 - Antennas don't tune correctly, high SWR, radiating coax
 - Your voice/transmission causes interference with consumer electronic devices acting as ham radio frequency “receivers” (e.g. computers, TV/audio system, security system, garage door opener, telephone, sprinkler systems, lights, etc.)
 - Spouse Alarm goes off! 
- **RX Symptoms** – caused by sources outside your radio
 - High receive noise level not due to atmospheric conditions
 - Birdies, chirps, buzzes, clicks, broadband noise on receiver
 - Distorted receiver audio

Typical RFI receiving “antennas”

- **AM broadcast, 160-80-60-40-30 meter RFI** – look for long “antennas” - AC power lines, telephone/DSL lines, satellite/cable coax, long Ethernet cables, antenna feed line coax shield, antenna control/rotor cables, 2nd story ground wires (avoid $\frac{1}{4}$ wavelength ground wires, e.g. 16 Feet)
- **FM broadcast, 20 meter to 450 MHz RFI**,– look for short “antennas” - speaker wires, device interconnect cables, mic cables, short Ethernet cables
- “Antennas” pick up radiated or conducted RFI which induces a common mode current on the SHIELD and ALL unshielded “antenna” conductors from an RFI SOURCE

So how do we reduce this current?

Stop RFI = Minimize Current

I (RFI Current) = E (RFI induced voltage)/R (Choking resistance)

- Shut down the SOURCE (Set E to zero)
- Choke the PATH (minimize I, increase $R > 1000 \Omega$)
- Protect the VICTIM (Set R very high, $>5000 \Omega$)



Objective: Minimize RFI current, I

Trivia Q: Why is current abbreviated with I and not C?

Ferrites are your friends to cure RFI



Ferrite Fundamentals

How to:
Select - Buy - Configure
and Apply



Ferrite Topologies (Shapes)



Slip On Bead



Snap On Bead



Toroid or Ring



Fuzzy Ferret – not!

FERRITE CHARACTERISTICS

- Cheap, easy to install, suppress RFI from 100 KHz - 2 GHz
- Work on all conductive paths (antenna & feed lines, AC/DC, I/O cables)
- Lots of options in size, shape, frequency range to suppress RFI currents
- Are effective if you understand how ferrites work, how to choose the correct ferrite and where to install the ferrite for a particular RFI problem

Ferrite characteristics can be used to reduce RFI common mode current

How do Ferrites Work?

Ferrites are frequency dependent “resistors”

Simple Equivalent Circuit

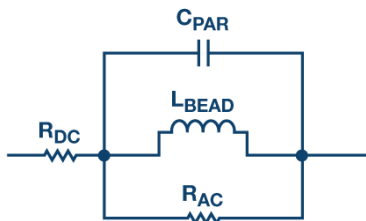

(a)

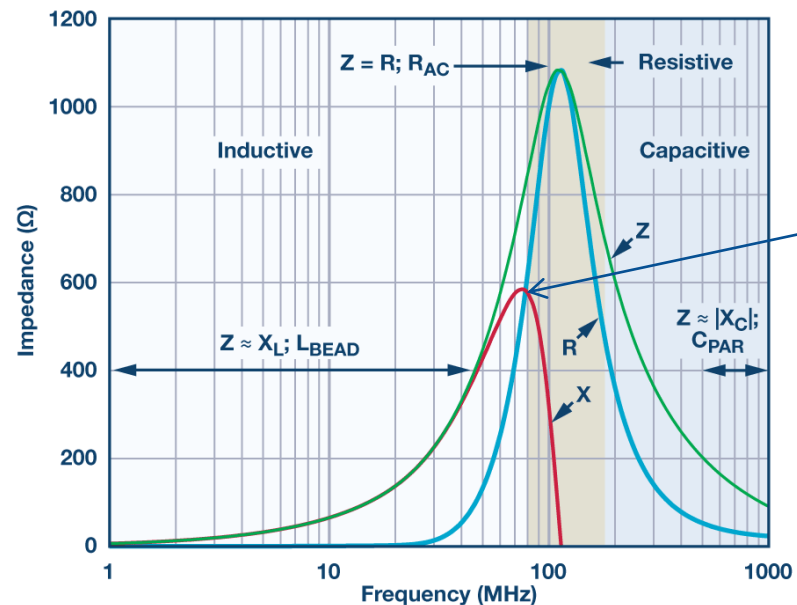

Blue Resistive region starts here - 80 MHz to 300 MHz

(b)

Ferrites are categorized by three response regions: inductive, resistive, and capacitive. To reduce high frequency interference (noise), the ferrite must be used in the resistive region where it acts like a resistor ($R = F(\text{MHz})$), which impedes the RF frequency noise (current) and dissipates it as heat.

How can resistance be increased?

Ferrites act like resistors-F(MHz)

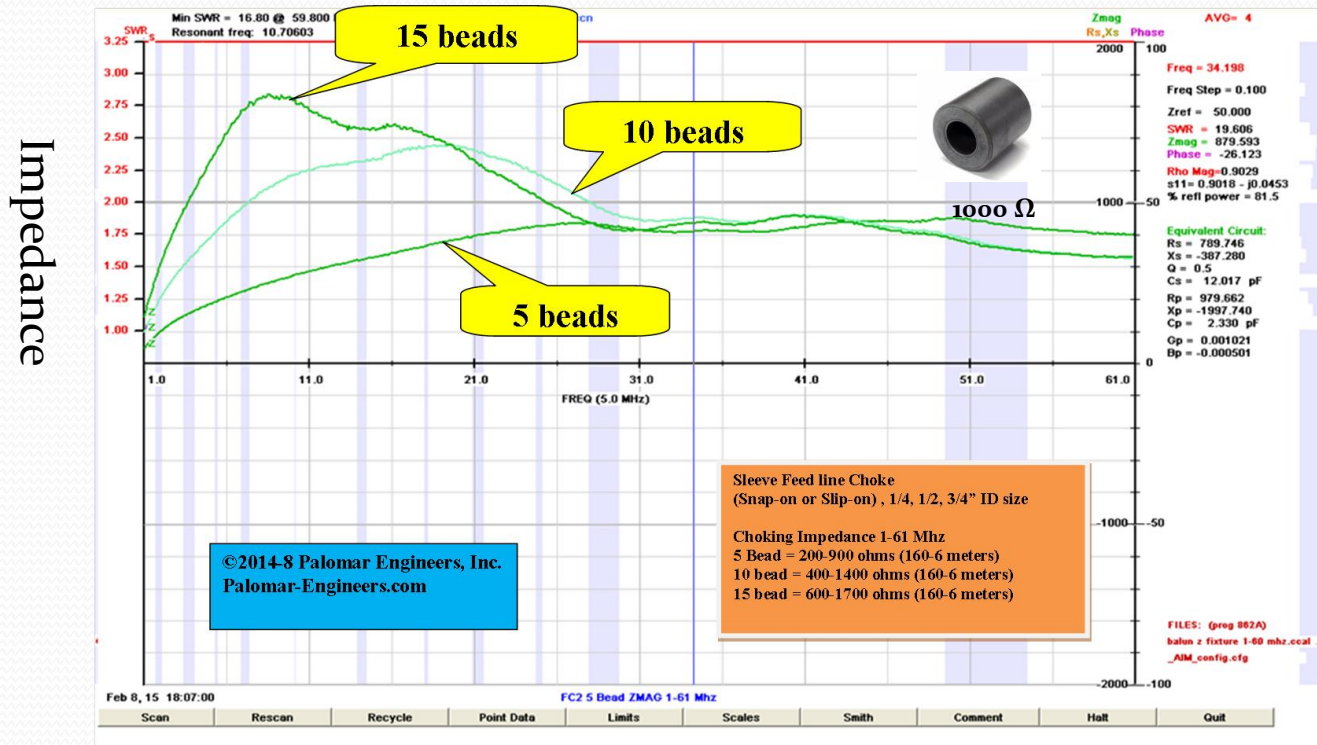

beads add resistance in series, but frequency dependent

higher choking R (up to 30 MHz in this example)

At 7 MHz:

5 beads = 400 Ω

10 bead = 1000 Ω

15 beads = 1600 Ω

Feedline Chokes



Frequency (1-60 MHz) \rightarrow

Impedance (Z) = Resistance +/- Reactance

Ferrites have one more additional very useful property...

Ferrite resistance increases as (turns thru center hole)²



- If 1 turn = R, 2 turns = 4 x R, 3 turns = 9 x R
- More R = less RFI wire current, I = less RFI radiated from wire or induced into wire. ($I=E/R$)
- **General rule: choking $R > 10X$ line impedance**
- (e.g. $> 500 \Omega$ for 50Ω cable but 5000Ω is 10x better)



1 Turn



3 Turn

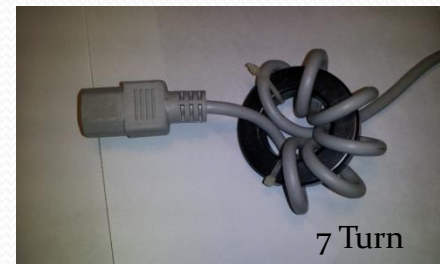

7 Turn

7 MHz: 100Ω (1 turn)

900Ω (3 turn)

4900Ω (7 turn)

Question: How do we choose the correct ferrite for the RFI frequency?

Ferrite composition (Mix) determines frequency range

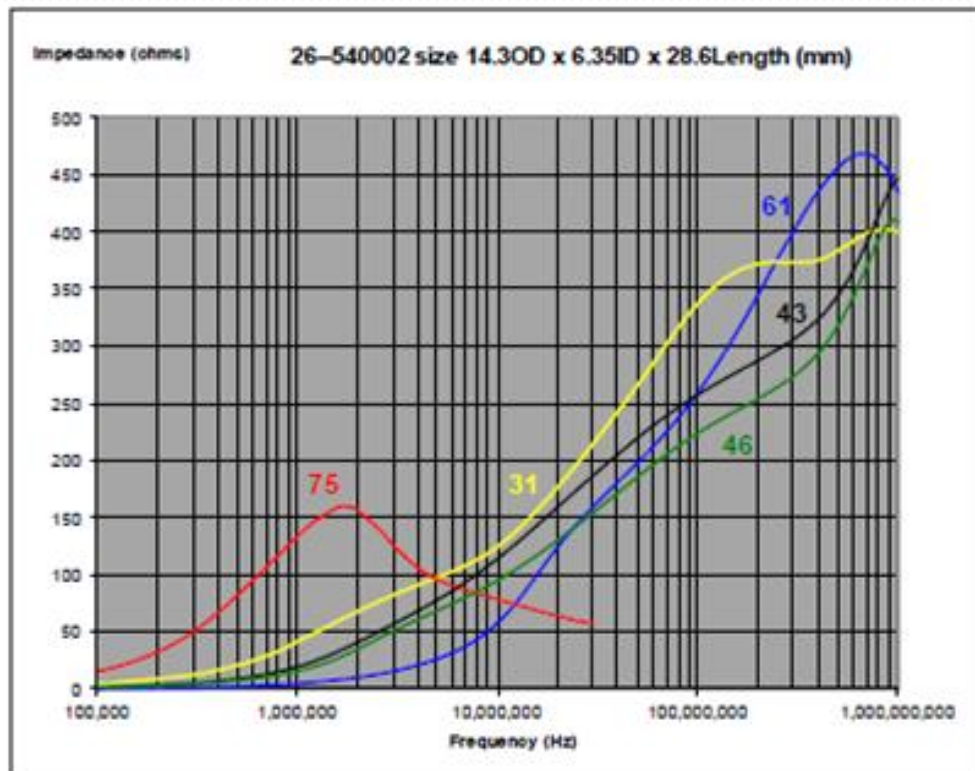

Mix = chemical formula of the iron oxide with manganese-zinc (31, 75) or nickel-zinc (43, 61)

RULE:

Select mix for max R at RFI
FUNDAMENTAL frequency
NOT frequency of receiver.

Example:

for .1-5 MHz use mix 75

for 1-300 MHz use mix 31

for 20-250 MHz use mix 43

for 200-2000 MHz use mix 61

Most popular ham frequency mixes are 31, 43, 61, 75.

Select mix based on RFI Frequency example – multi-bead sleeve choke

Match RFI Frequency to Mix

Mix 75 up to 10 dB better than Mix 31 under 3.75 MHz!

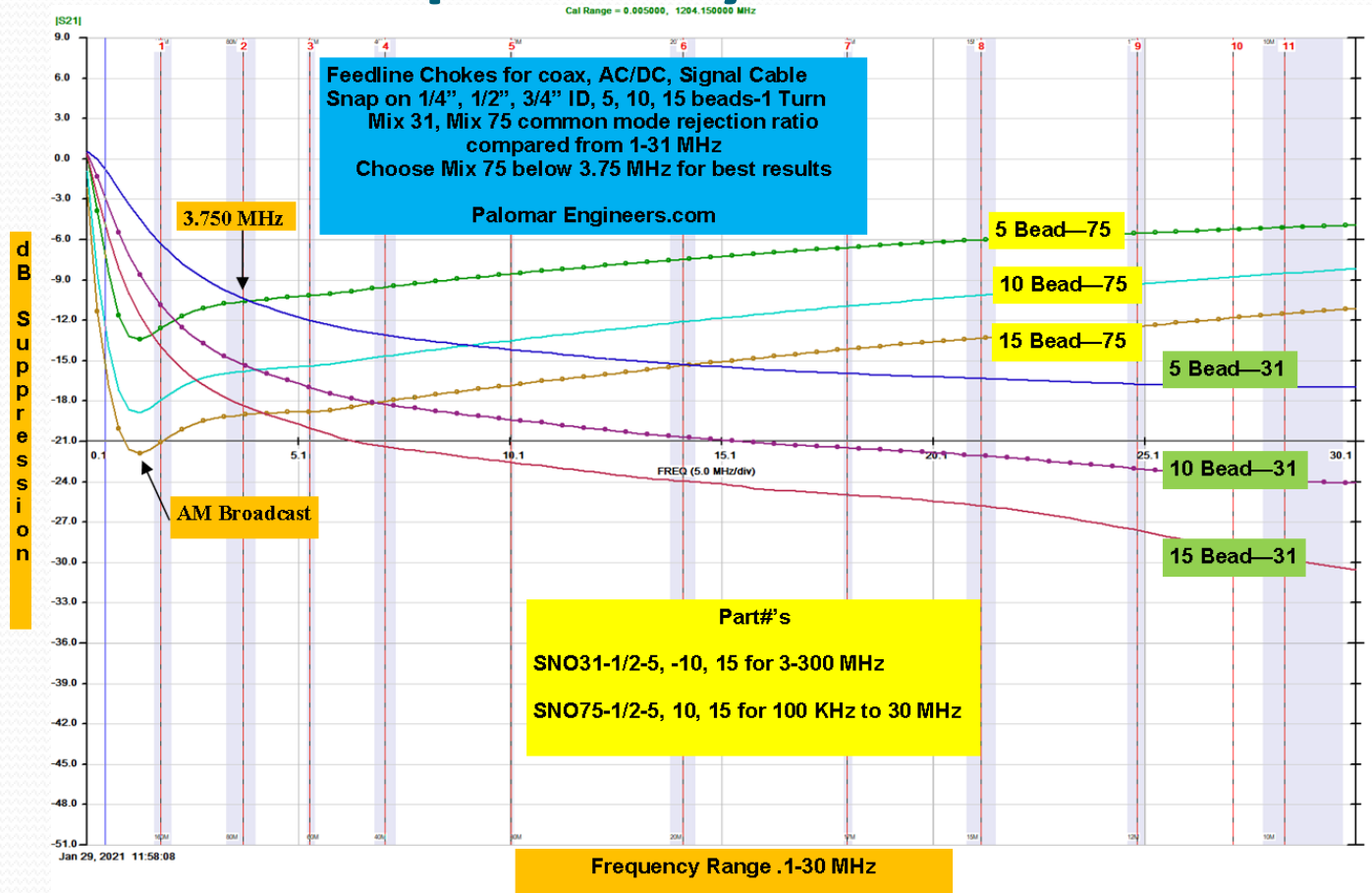

Selecting wrong or unknown mix will probably not work so.. How NOT to buy

How NOT to buy ferrites!



Amazon/eBay



Swap meet

=

DON'T

BUY!!!

- NO Mix Designation
- NO Resistance/Impedance Range
- NO Frequency Range = No No No!
- Like Buying a resistor with no color bands (unknown resistance)!

Buying unknown ferrites is like buying a box of rocks - a waste of time and money!

Another Alternative?

How to buy Ferrites the **right** way!



Ferrite Split Bead
10 Pack -1/2" ID – Mix 31
RFI Range: 1-300 MHz
Part#: FSB31-1/2-10

Single turn, each bead provides:

MHz	5	10	25	100	250
Ω	71	100	156	260	260

(2 turns=4X Ω , 3 turns =9X Ω , 4 turns = 16X Ω)

AC/DC/Coax/Audio-Video/Data Cables

Use multiple turns for best results

=

**BUY With
CONFIDENCE!!**

Product Labeling (Mix, Frequency, Impedance) + Known Vendor = Winner!

So let's recap RFI 101

Ferrite Use Recap

- Determine RFI interfering frequency & suspected Path
- Choose proper mix (31, 43, 61, 75) to suppress RFI fundamental frequency
- Choose Topology (slip-on, snap-on, ring) to fit the Path
 - Install ferrites on path – retest for RFI suppression
 - Consider additional ferrites or paths if RFI persists

Most popular Mix for HF is MIX 31 (1-300 MHz)
(Mix 75 for .1-5 MHz, Mix 61 for 200-2000 MHz)

Subtle Note: Mix frequency ranges shown are for RFI suppression only. Mix frequency ranges for use as impedance transformers (2:1, 4:1, 9:1, 49:1, etc) are different. NEVER use mix 31 for an impedance transformer as it has too much resistance and will heat up & easily saturate at low power.

How and where do you put the ferrite filter for transmitter RFI?

GOAL:

STOP TRANSMIT RFI

Tip # 1: RFI Kits for HF Transceivers and Linear Amps

Tip # 2: Minimize coax cable radiation (HF or VHF)

Tip # 3: Install Solution Specific RFI Kits for VICTIMS



Tip #1 - Install Transceiver, Linear Amp RFI Filters

**Goal: Minimize SOURCE RFI from radio and
amplifier cables acting as radiating “antennas”**



RFI Filters for Transmitters/Amps

- Transmitter – Amplifier - Antenna RFI suppression
 - Choke ALL cables into/out of radios, amplifier, antenna tuners
 - Includes
 - Coax RF feed lines at antenna feed point to suppress TRANSMIT RFI
 - Rotor/Antenna Control lines
 - AC/DC power Lines including wall warts!
 - Computer – all radio interconnects, AC power
 - Examples on next slides
- Recommendation: Filter ALL cables to equipment using Palomar transceiver, amplifier and computer RFI kits with mix, sizes, instructions already pre-determined by brand.

Buy it – Install it – Problem solved!

Power Supply, Transceiver/Amp Example

Switch Mode Power Supply Filters

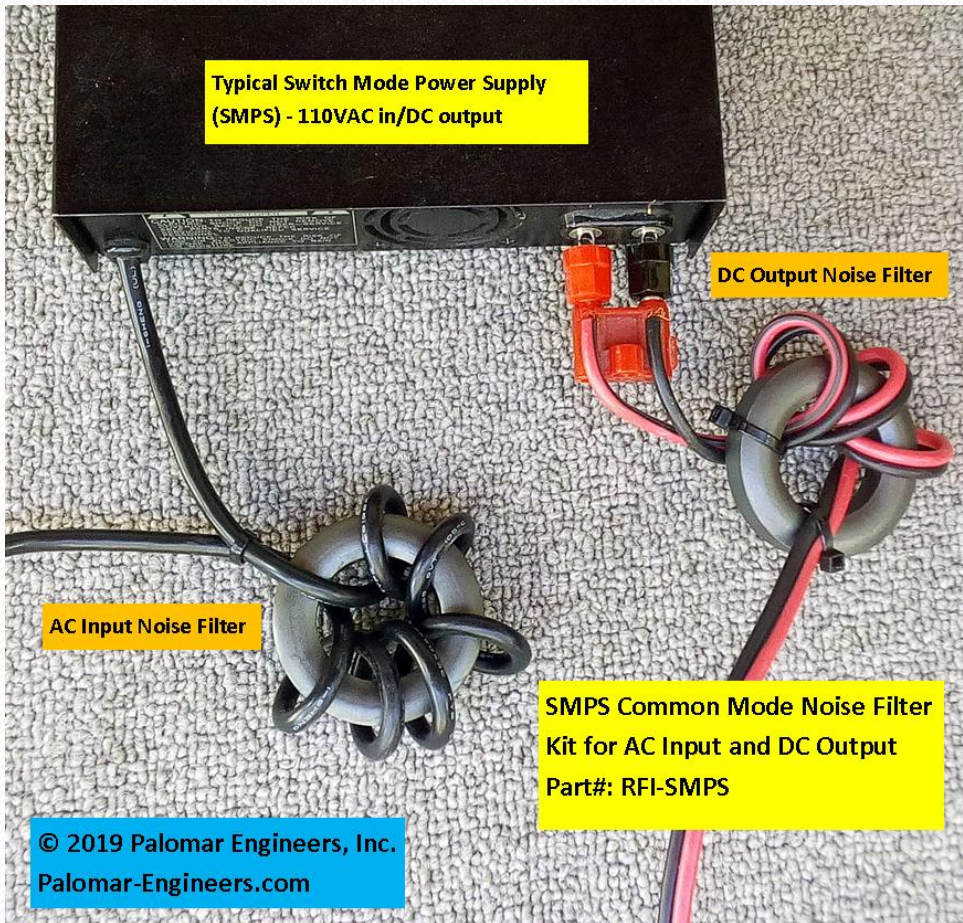

SMPS may act as an RFI transmitter and uses DC cable and AC power line as its “antennas” – so filter both lines using Mix 75 to suppress switching frequency fundamental (< 2MHz) and all harmonics in ham bands.

Part# RFI-SMPS

Transceiver Kits

Transceiver RFI Kits

Palomar has RFI kits for all brands of transceivers

Transceiver Standard RFI Kit

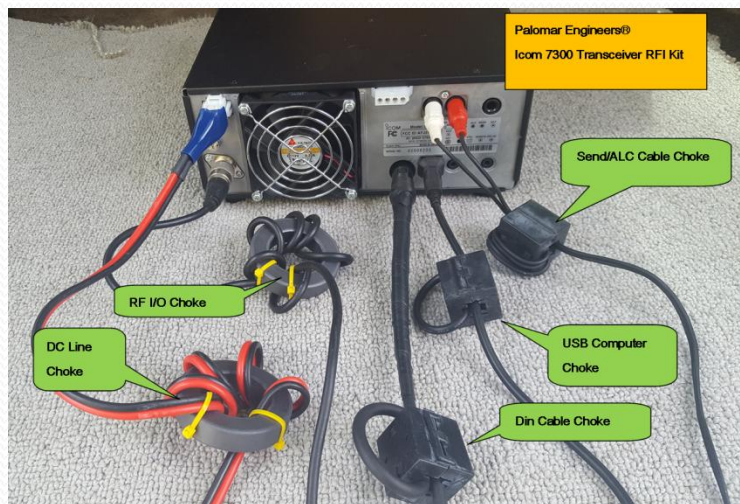

ICOM 7300

Transceiver Deluxe RFI Kit with NF

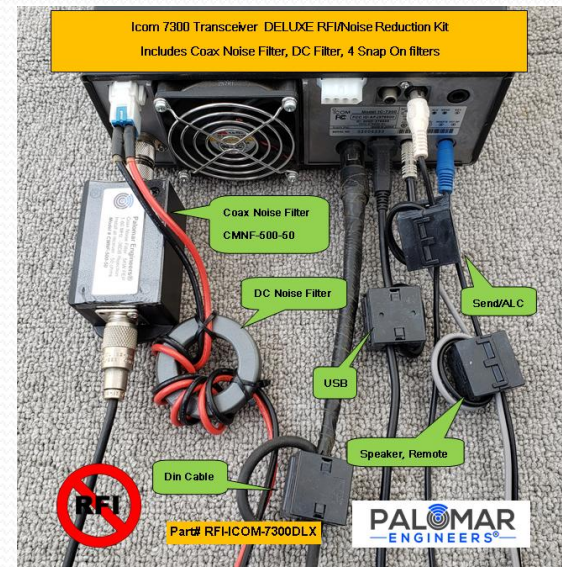

RULE: Clean up the RFI SOURCE first – your radio

Linear Amps too!

Linear Amplifier RFI Kits

Palomar has RFI kits for all brands of linear amps

Transceiver RFI Kit

Linear Amplifier RFI Kit

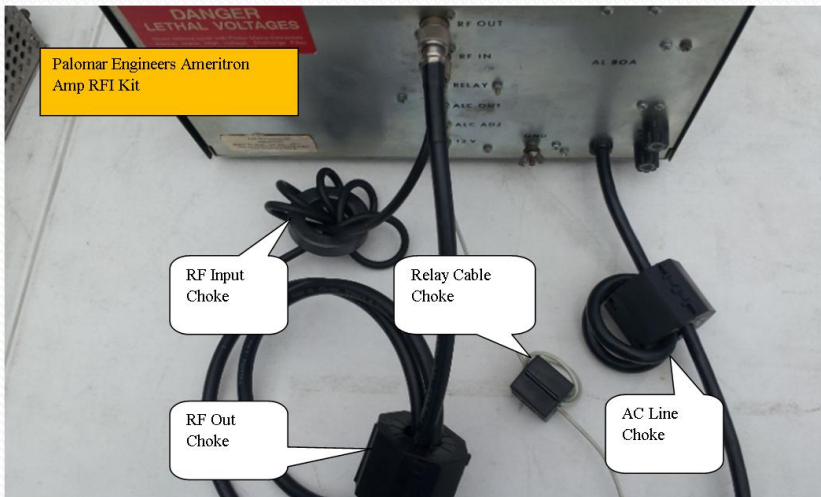

Ameritron 811

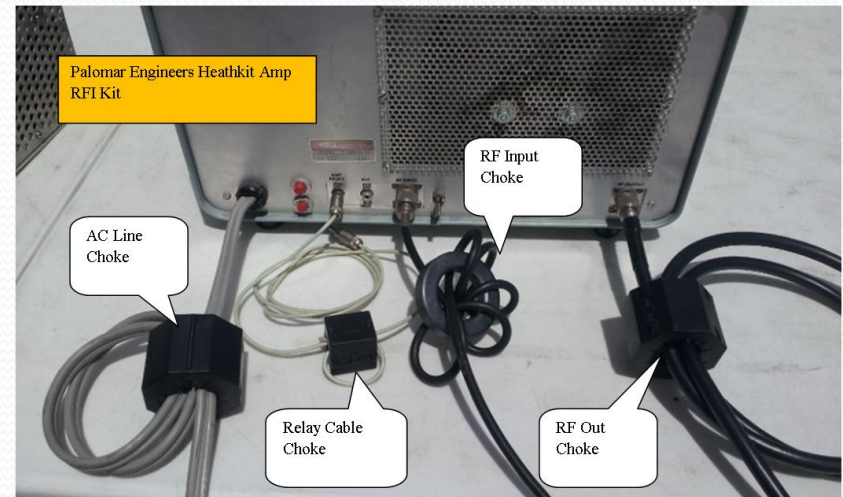

HEATHKIT SB220

Clean up the RFI **SOURCE** first – your radio and amp

Solution Kits for Tube and Solid State Amps

Now coax feed lines

Tip #2. Stop Transmit RFI current on coax braid



ALL coax fed antennas need a feed line choke at the antenna feed point!!!!

OR

Your dipole will become a tripole or
Your unipole (vertical) will become a dipole
and your coax may radiate causing local RFI!

Is your Dipole a Tripole?

- Coax outside of braid acts as extension of transmitting antenna and extra receive antenna

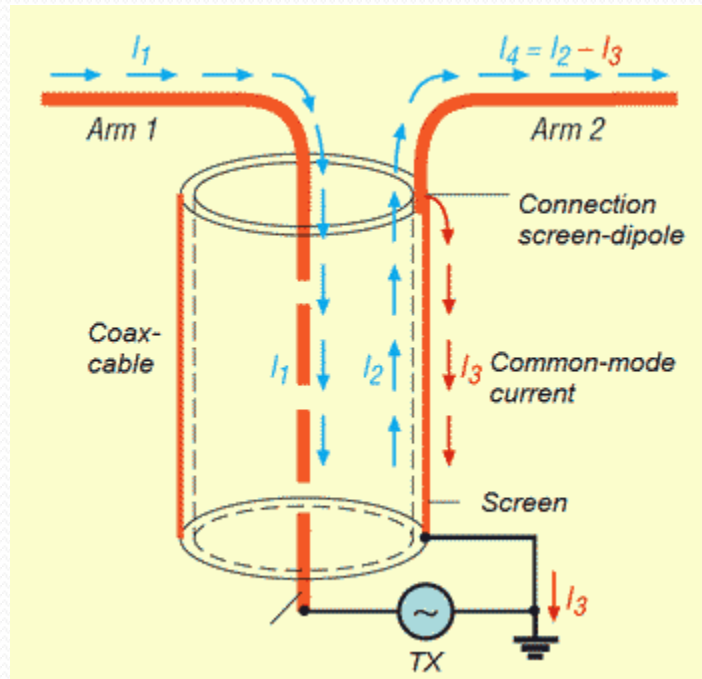

Coax cable has 3 conductors!

Coax braid is actually 2 conductors :
1 on the inside (normal RF signal), and
1 on the outside (common mode current)
that turns a dipole into tripole on transmit
or a second antenna on receive!

Goal is to reduce common mode current
with a feed line choke to keep all transmit
RF on antenna and use a coax noise filter to
minimize noise into receiver.

FYI: 5% common mode braid current = 13.75 watt radiation at 1500 watts output, or 8 watts at 500 watts output or 3.5 watts at 100 watts output

Typical Coax Fed Antenna System

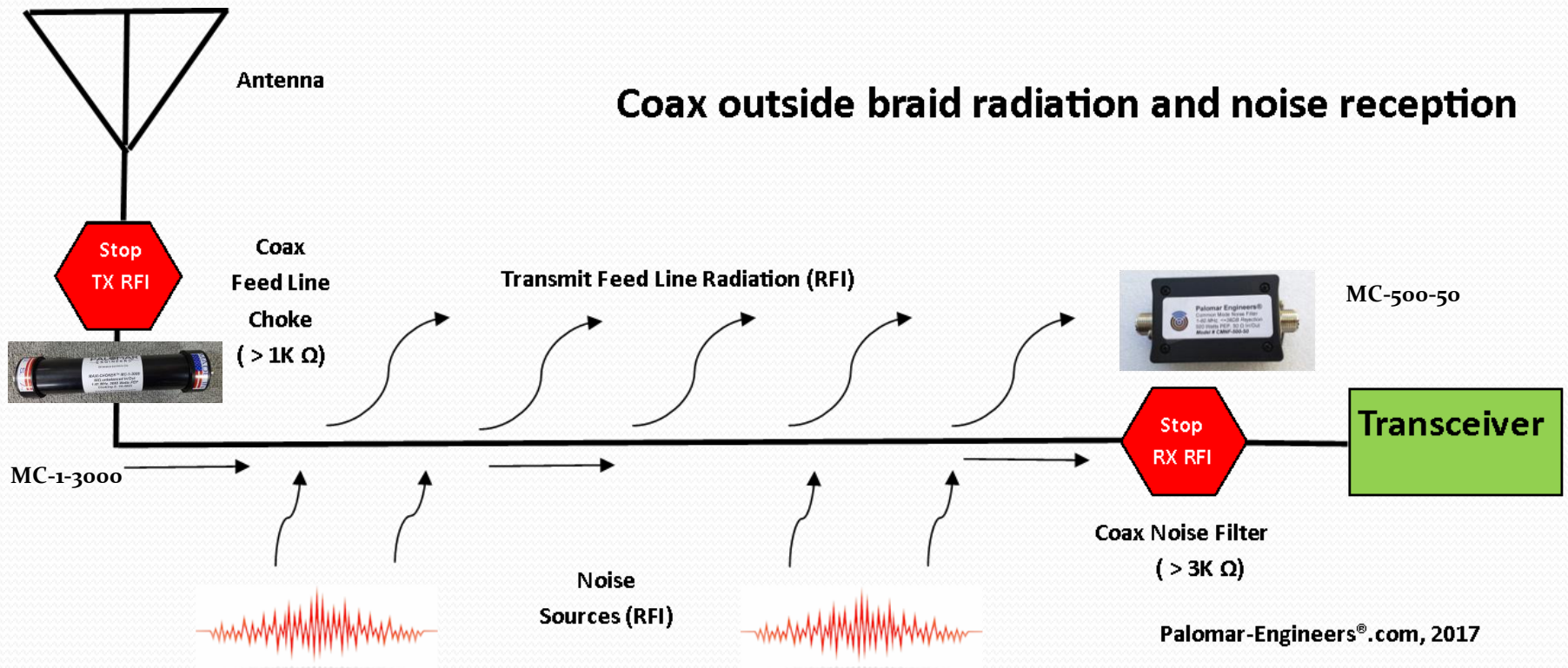

Technical requirements for feed line choke selection

Choose choking resistance > 10000Ω over frequency range used

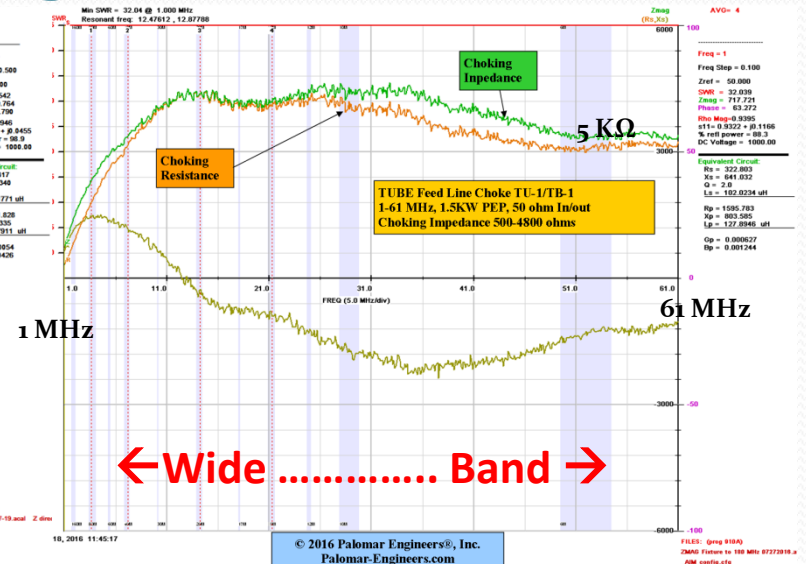
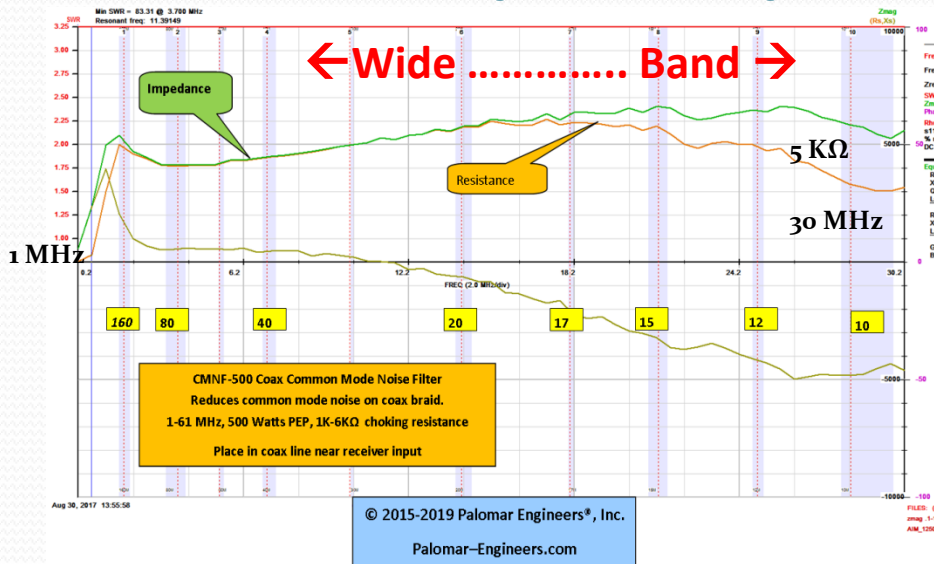

Coax Noise Filter (CMNF-500-50)
1-65 MHz >2K
500 Watts PEP, Up to 38 dB reduction (6 "S" units of common mode noise gone!



Line isolator (part# MC-1-3000 - 3KW PEP)
1-61 MHz >2K, 3KW PEP, 1K-6K ZΩ, 1 pound. All coax lines, Optional ground, static bleeder, up to 38db suppression!

Same data measured on VNA as CMRR →

Choose choke with CMRR > 20 dB over frequency range used

CMRR =
Common Mode
Rejection Ratio

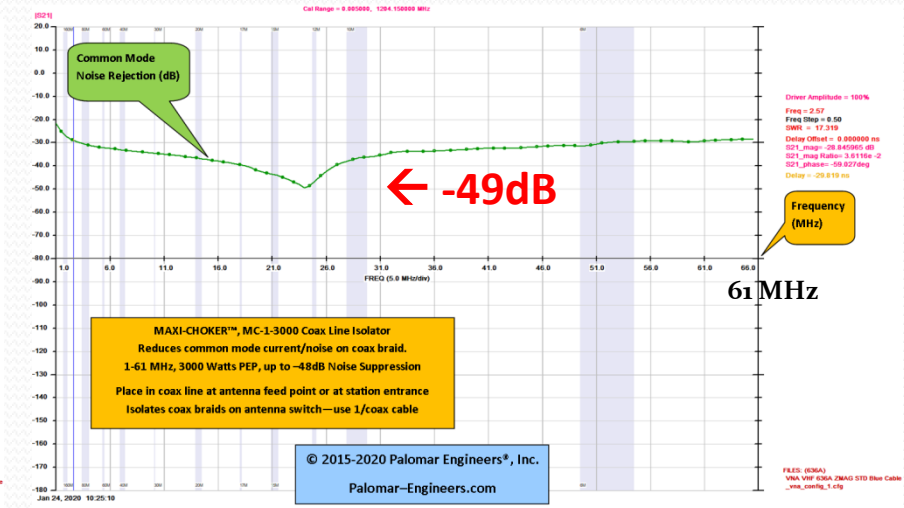
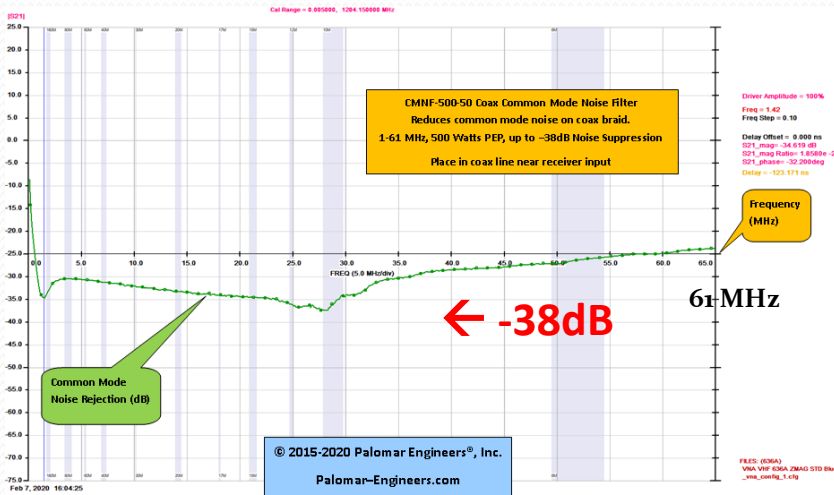

Coax Noise Filter (CMNF-500-50)
1-65 MHz >2K
500 Watts PEP, Up to 38 dB reduction (6 “S” units of common mode noise gone!



Line isolator (part# MC-1-3000 - 3KW PEP)
1-61 MHz >2K, 3KW PEP, 1K-6K ZΩ, 1 pound. All coax lines, Optional ground, static bleeder, up to 49 dB suppression!

1 “S” unit = 6 dB, 36 dB = 6 “S” units

DO NOT BUY CHOKES with NO SPECS!

Chokes for Antenna Feed Point



3KW Maxi-Choker™ on beam



1:1 Balun = choke with balanced output – dipole antenna



Hybrid Baluns – 4:1 + 1:1 in same enclosure – OCF, Loop Antennas

Neighbor Victim RFI

Tip #3. Install Solution Specific RFI Victim Kits

Our Goal: Minimize Transmit RFI to Electronic Devices in your home
or your neighbor's homes



OR



Neighbor RFI Strategy →

Neighbor's RFI Strategy

- Choke RFI SOURCE – YOU!



Ham's Strategy is different!

Ham's Solution to Neighbor's RFI

- Source (transmitter or antenna) – Path – Victim
 - Clean up your transmitter/shack first using techniques already discussed
- Assess Neighbor's Problem
 - Faulty device (device acting as receiver when not designed to be a radio receiver – e.g. Telephone, HDTV)
 - Determine frequency of “transmitter” that is causing the problem (may not be on all bands – may not be you!)
 - Find the path (or paths) to the Victim (Receiver)
 - Choose the RFI choke kit for the frequency and path
 - Choke the path, protect the device (externally)!

Simple RFI Detector to the Rescue!

SignalPen® – Simple RFI Detector



- **SIGNALPEN™**
- **Self Powered Pencil Size RF Detector Light**
 - 60 Hz to 1.2 GHz
- **Milliwatts to Kilowatts Direct Contact or Inductive Detector, No Battery!**
 - Proximity Range: .5-3Ft
- **Part# SIGNALPEN**

Transmit RFI Solutions

MY HOME or NEIGHBOR'S HOME



ALARM SYSTEM RFI



HOME THEATER RFI



COMPUTER RFI



MISCELLANEOUS RFI



GARAGE DOOR



TELEPHONE/DSL RFI

Recommendation: Use RFI kits for specific problems, have neighbor purchase and install – do not make mods to neighbors equipment! MOST problems are RFI picked up by AC power/phone lines so ferrite filters work well.

RFI proof your transmissions recap

- Determine frequency range of RFI and Path
 - Install transceiver and amplifier RFI kits to suppress RFI
- Install a feed line choke in ALL antenna coax lines of your station at the antenna feed point with enough choking impedance at the frequency of use to minimize coax braid radiation
- Install AC/DC power filters on affected equipment and retest for RFI suppression
 - Consider additional filters and paths if RFI persists

If you need help

Call or email (sales@Palomar-Engineers.com) or view specific solutions at **Palomar-Engineers.com**

What about receiver noise? →→

GOAL: **SUPPRESS** RECEIVE RFI

Tip # 4: Install Coax Noise Filters if needed

Tip # 5: Identify & Suppress Local RFI/Noise Sources

Tip# 6: Isolate Antenna Switch coax braids



Receiver RFI Noise Strategy

- Assess S-P-V for the RFI – You or someone else is source?
- PROTECT the VICTIM (Your receiver)
 - Ferrites on AC/DC cords, Wall Warts – ring or snap on ferrites
 - Coax noise filters on antenna feed lines, ferrites on rotor lines
 - Ferrites on radio to computer interconnect cables
- ELIMINATE/ISOLATE the SOURCE
 - Choke AC/DC power to source, snap on ferrites for all I/O
- Call Palomar Engineers if you get stuck or need help

AC/DC power filtering

RFI – AC/DC Power Line Chokes

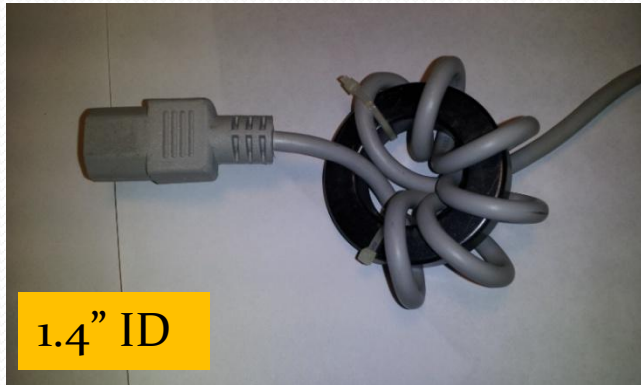

Choose mix frequency range and size to fit cable – use max multiple turns

Refrigerators, Washer/Dryer, motors, routers, appliances

Coax RFI

Receive Coax RFI Problem

- Symptoms: High noise levels, spurs, buzzes, periodic signals across bands

Coax braid acts as 2nd receive antenna and combines with “real” signal at connector!

Typical Receive Chain Connections

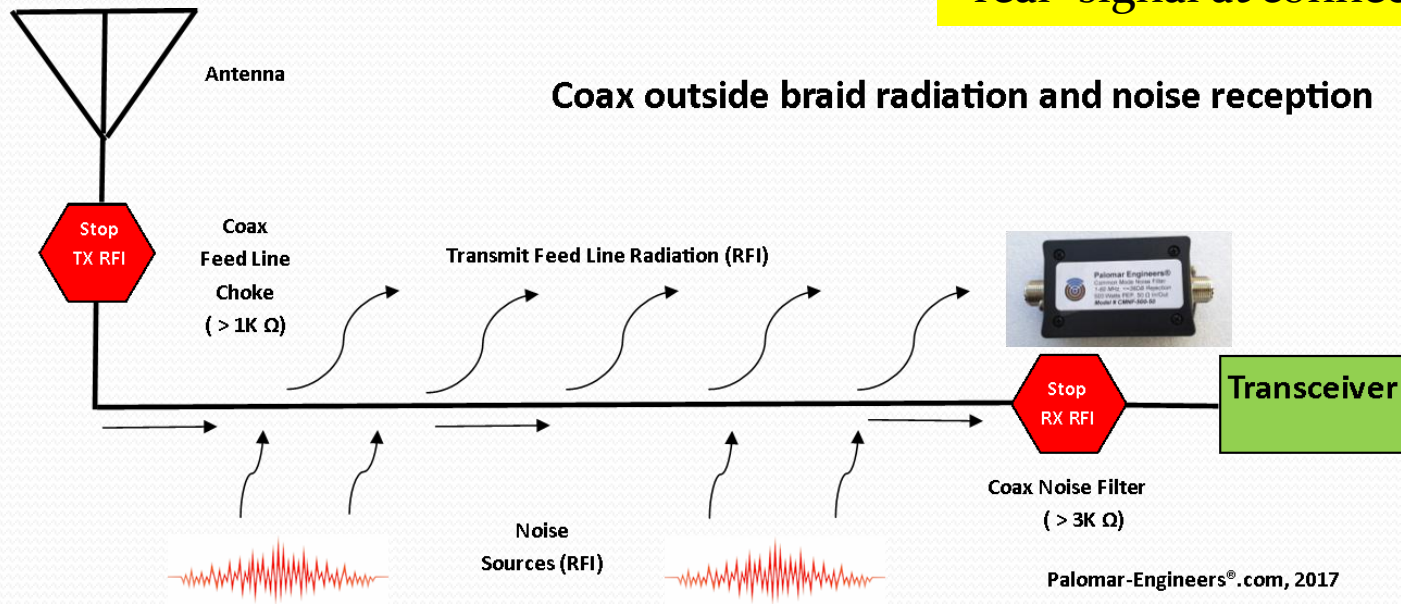

Palomar-Engineers®.com, 2017

Simple common mode noise test →→

Tip #4. Install Coax Noise Filter to Suppress RX RFI

Less common mode noise current (RFI) = More DX!
How to select and install filters for maximum effect

Quick Test
for Common
Mode RFI

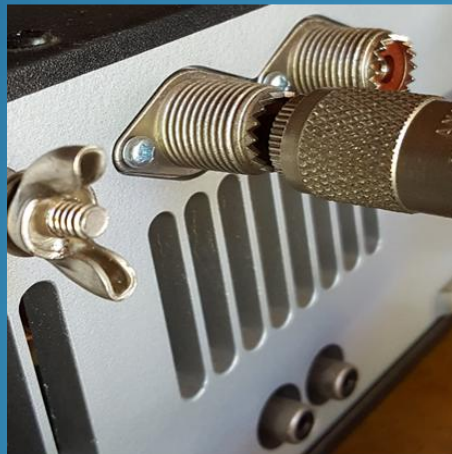

Coax Center Conductor Only—measure noise level

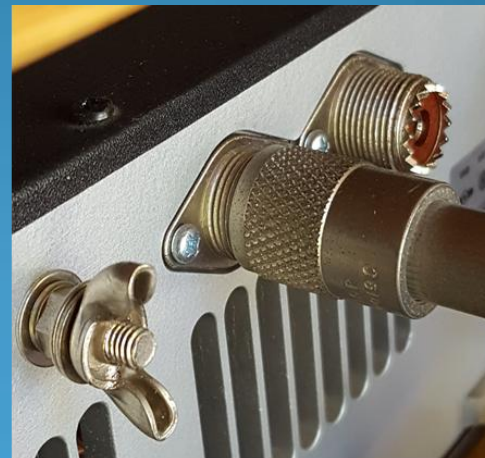

Coax Center Conductor and outer shield — measure noise level. If higher, then you have common mode noise

Best kept secret!



Coax Noise Filter Specs

TOP SECRET

>>> One of the best kept secrets in ham radio!!! <<<

1.5KW
or
5KW



500
Watts

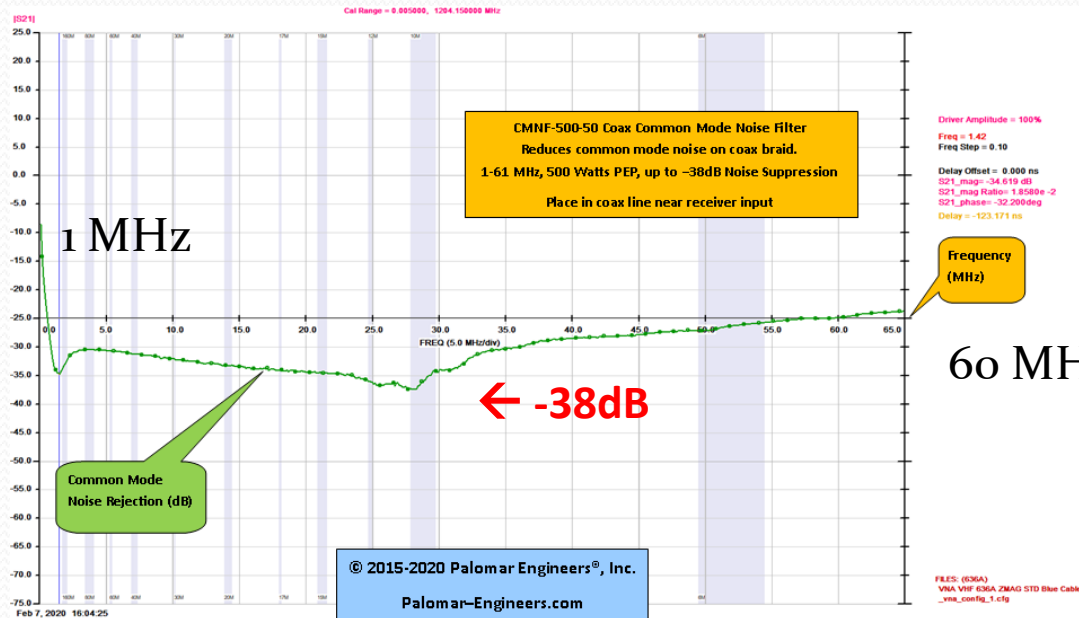

Placed at RADIO END of coax feed line to suppress common mode current on coax braid between antenna feed point choke and radio

1 "S" unit = 6 dB, -36dB = 6 "S" Units

Station Install Points

Coax Noise Filter Installation

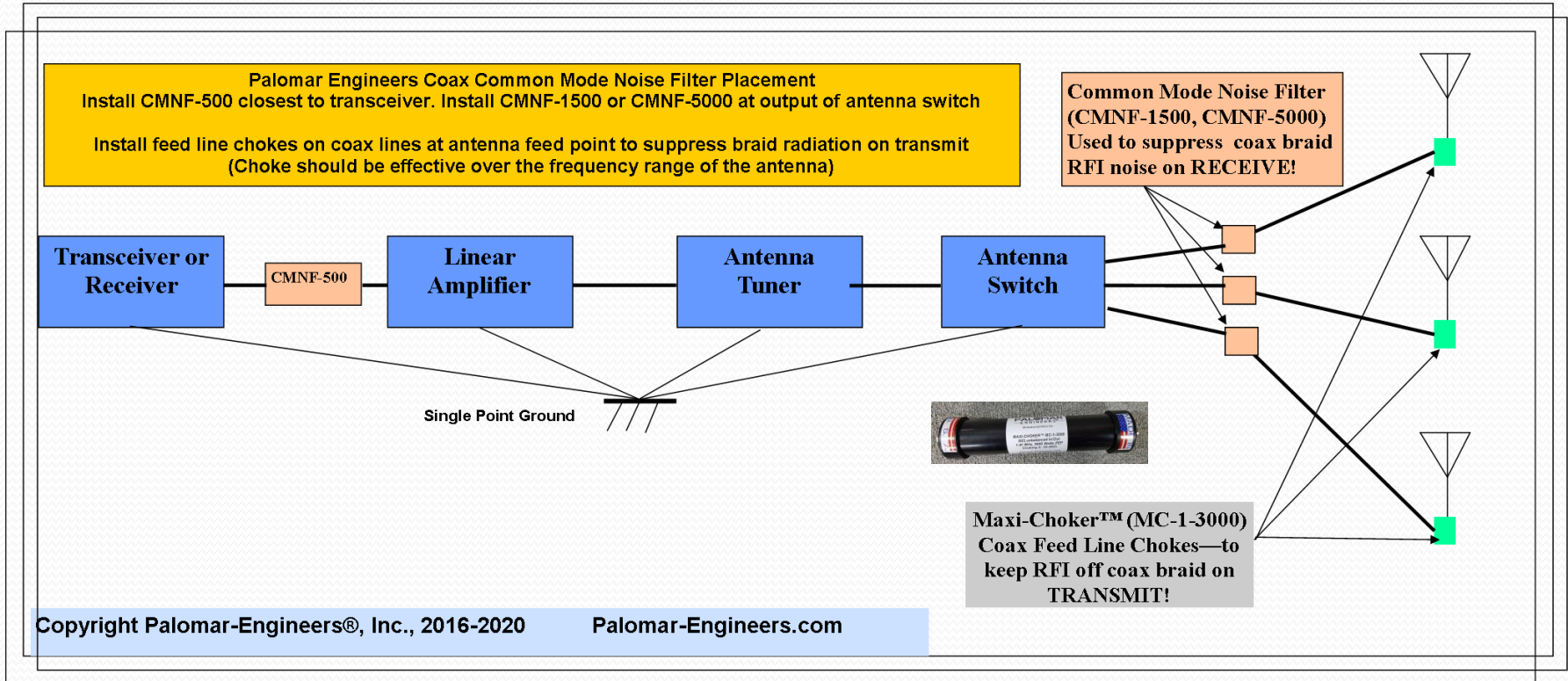

Where to Install

- Choke at antenna for TRANSMIT RFI
- Noise Filter at Antenna Switch for RECEIVE RFI
- Between Transceiver and Amplifier
- Single point ground system

Antenna Switch Solution

Antenna Switch Solution

ANTENNA SWITCH PROBLEM
 During RECEIVE, you have 2 RECEIVE antennas per coax: the signal down the center of the coax + the signal picked up by the outside braid of the coax and they COMBINE at the coax connector unless suppressed by a coax noise filter! All coax braids are connected at the switch so you may be hearing noise from the braid of an unselected antenna! Use filters on each coax line before the switch!

TRANSCIVER OR LINEAR AMPLIFIER

Antenna Switch (only switches center conductor)

If no common mode noise filters, noise = CN1+CN2+CN3 regardless of antenna switch position!
 You always have 4 antennas—1 center and 3 braids!
 CN1=common mode noise on coax braid 1, etc.

Mini/Maxi-Choker™ or Common Mode Noise Filter used to suppress coax braid RFI noise (CN1, CN2, CN3) during RECEIVE!
 MC-1-500 = 500 Watts
 MC-1-3000 = 3KW
 MC-1-5000 = 5KW

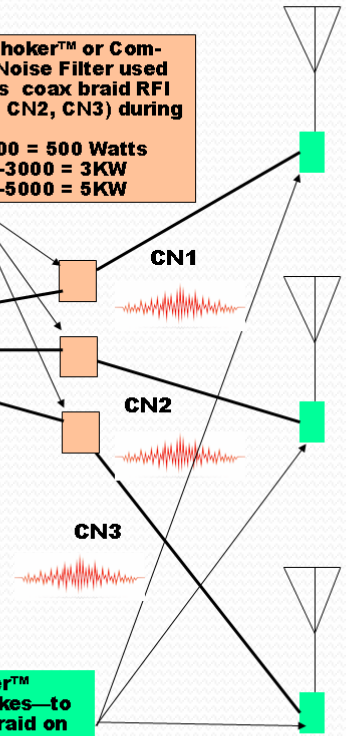

For common mode and RFI solutions contact Palomar-Engineers®.com

Mini/Maxi-Choker™ Coax Feed Line Chokes—to keep RFI off coax braid on TRANSMIT!
 MC-1-500 = 500 Watts
 MC-1-3000 = 3KW
 MC-1-5000 = 5KW



**500 watt Coax Noise Filters
 2 port switch = 3 RX antennas!**



Coax Braid Isolators

RFI/Noise Fix for FLEX Station

Palomar Engineers®.com
FLEX RADIO SYSTEM INSTALLATION DIAGRAM—SO2R OPTION
RFI Kits Shown: RFI-FLEX-6400/6600, RFI-LA-FLEX, RFI-AT-FLEX-TG, RFI-AS-FLEX-AG

Palomar Engineers Coax Common Mode Noise Filter Placement
 Install CMNF-500 closest to transceiver. Install CMNF-1500 or CMNF-5000 at output of antenna switch
 Install feed line chokes on coax lines at antenna feed point to suppress braid radiation on transmit
 (Choke should be effective over the frequency range of the antenna)

Use 3KW Maxi-Chokers™ or
 CMNF-500 Coax Noise Filters
 to suppress coax braid noise
 between antennas on receive!

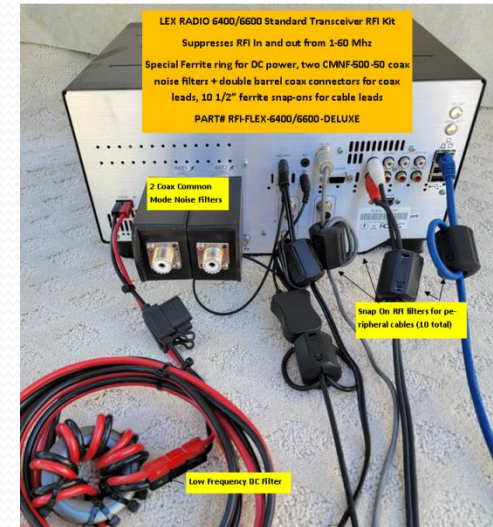
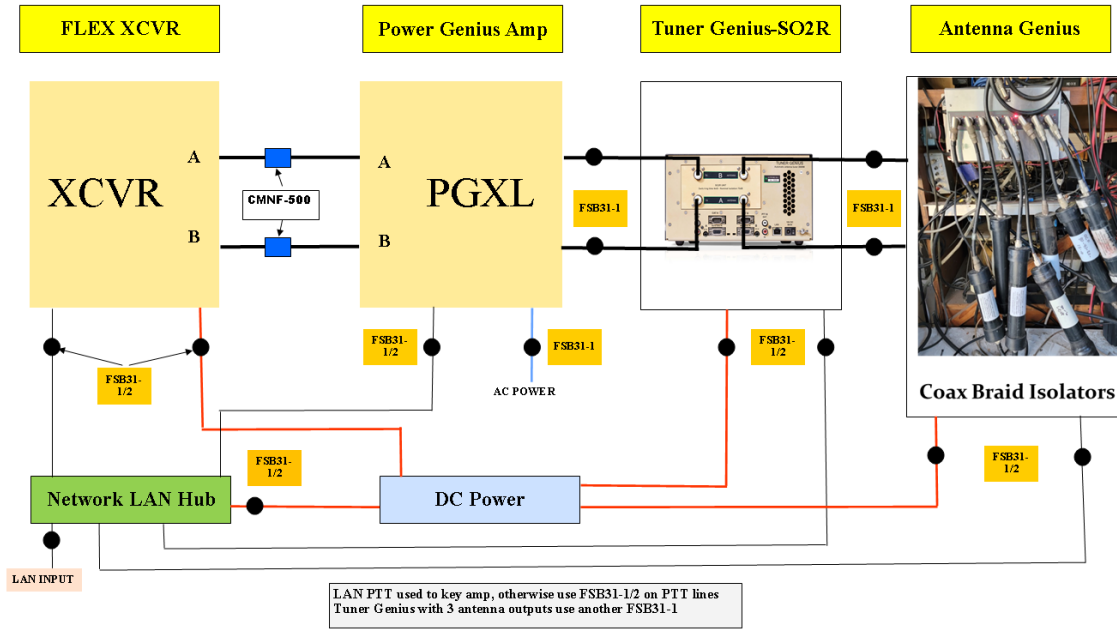

Suppress RFI Receive Noise Recap

- Perform simple noise test on your radio
 - Unplug your antenna and see if all the noise goes away – if not, noise is entering from another wire into radio – probably power supply – install transceiver RFI kit on all lines
 - Perform common mode test with antenna coax – if noise increases when you screw in the outer coax connector you have common mode noise and need a coax noise filter. IF no change then ferrite filters won't help and you will have to kill the path or stop the SOURCE
 - If you have an antenna switch unplug all antennas and perform the above test on each antenna coax individually and install coax noise filters as needed
- Consider additional filters and paths if RFI persists

If you need help

Call or email (sales@Palomar-Engineers.com) or view specific solutions at **Palomar-Engineers.com**

What if you are a ferrite newbie? →→

Receive RFI Solution

Transmit RFI Solution

Tip #7. Use Ferrite Combo RFI Kits for Newbies

Ferrite Combo Kits for Troubleshooting Multiple RFI Issues include multiple ferrite shapes and sizes

or

½” ID snap-ons and 1.4” ID rings are the most popular sizes and can be used to solve most ham radio HF RFI problems



Mix 31
RFI Range: 1-300 MHz



Palomar-Engineers.com

Buy 9
Get 1
FREE!



Use Discount code “NEWBIE25” – get 10% off orders thru 12/31/2025

Test Time

Question #1

- What are the 2 best ways to increase the choking resistance of a ferrite filter?
 - A) Use high resistance wire and multiple turns on bead
 - B) Use multiple turns and double shield coax
 - C) Use multiple beads in series with multiple turns
 - D) Use mix 31 and mix 75 beads in series with a single turn

Question #2

Mix 61 is used in which frequency range to suppress RFI common mode current?

- A) 1-300 MHz
- B) 200-2000 MHz
- C) .15-5 MHz
- D) 1-2000 MHz
- E) CB Band Only

Question #3

TOP SECRET

- What is one of the best kept secrets in ham radio?
 - a) Ladder line has more loss than coax
 - b) A coax wound choke can cover all frequencies from 160-6 meters if the coax is long enough
 - c) All ferrites work on all frequencies, so buy the cheapest
 - d) Coax noise filters reduce common mode noise level in your receiver so you can hear more stations
 - e) All extra class hams go to heaven

BONUS Question

Bonus Question #4

- Which company is your best source for RFI & HF Wire Antenna solutions?

The logo for Palomar Engineers features the word "PALOMAR" in a large, bold, black sans-serif font. The letter "O" is replaced by a blue graphic of concentric circles with three curved lines above it, resembling a signal or antenna. Below "PALOMAR" is the word "ENGINEERS" in a smaller, blue, all-caps sans-serif font, with a registered trademark symbol (®) to its right. Two horizontal lines, one on each side, extend from the base of "ENGINEERS".

PALOMAR —ENGINEERS®—

RFI Solutions from KHz to GHz

- Website: Palomar-Engineers.com
- Email: Sales@Palomar-Engineers.com
- Phone: 760-747-3343
- Bob Brehm, AK6R – Chief Engineer
- This presentation available on the website.

Simple DIY Feed Line Chokes



\$10

Simple Dipole Choke

Keeps RF off coax braid—prevents dipole from becoming a tripole



\$30

Coax Jumper Feed Line Choke

Effective range: 3-30 MHz
Choking Impedance: 500 - 2,500 Ω
Power Capability: 1500 watts PEP
Part#: JC-1-1500/OCFFLC
Choke Application: Dipoles, OCF, Yagi
Isolator Application: XCVR to AMP

© Palomar Engineers, Inc., 2020
Palomar-Engineers.com
All Rights Reserved

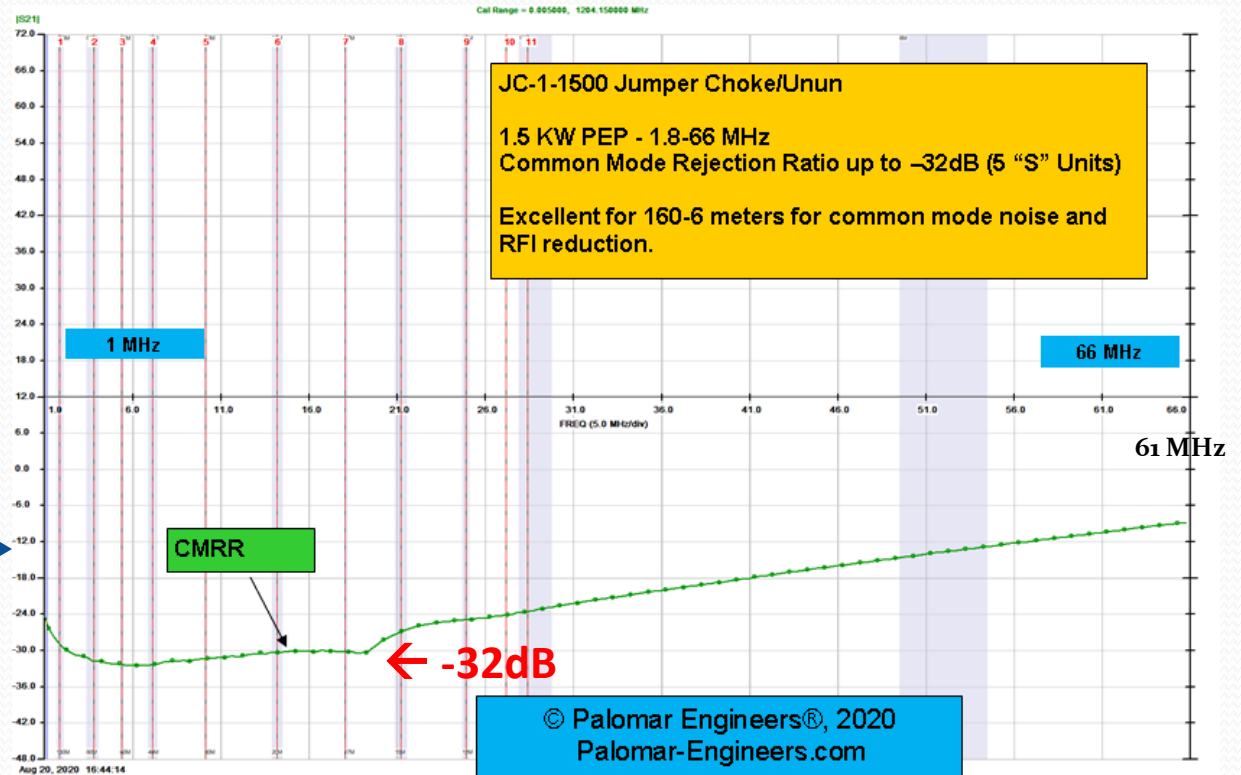

For HF use Mix 31, 1.4" ID Ring with multiple turns
(10 turns = -32 db Common Mode suppression)

Next: Multi-bead chokes

Multi-Bead Chokes (Slip-On/Snap-On)

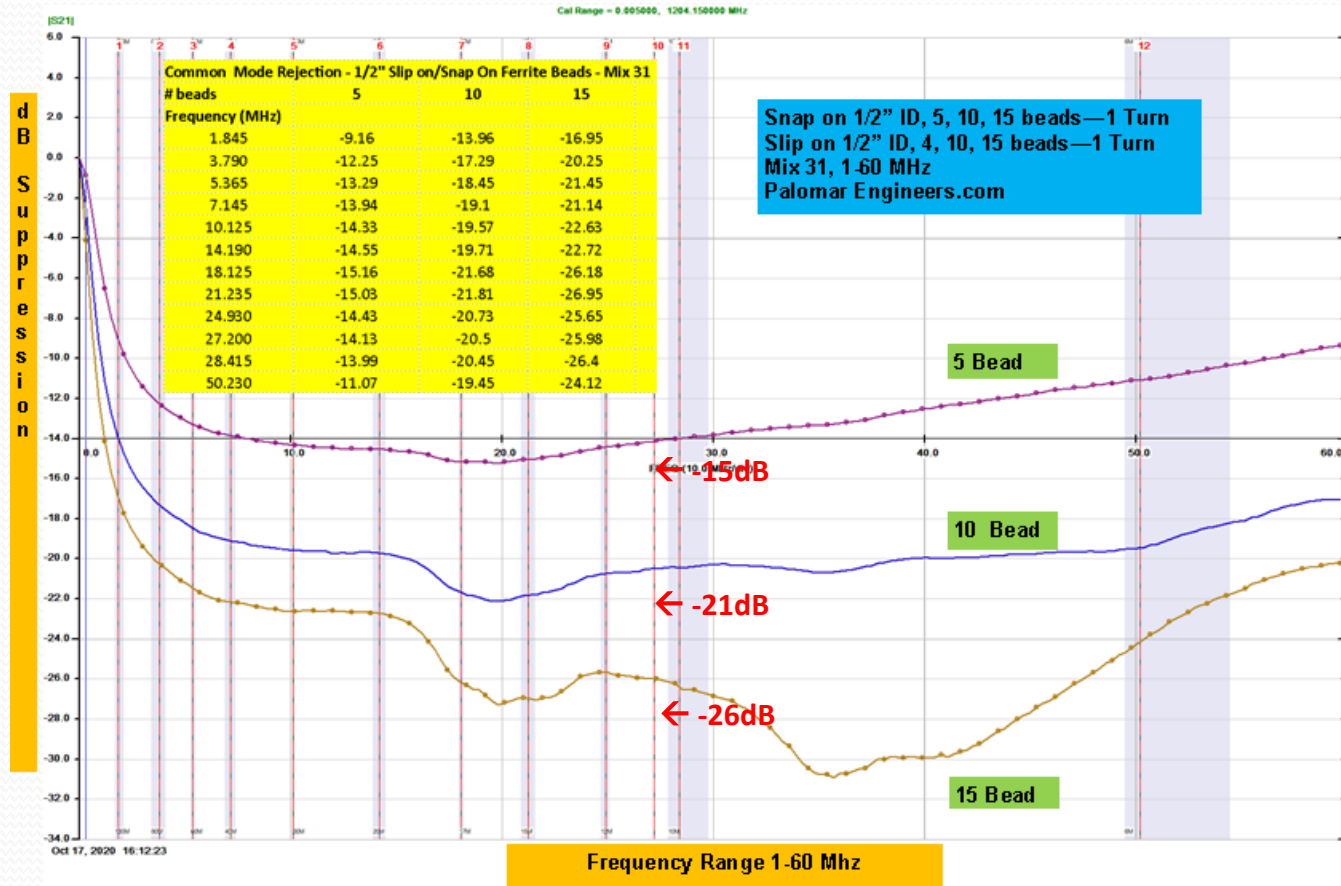

1/4, 3/8, 1/2, 3/4, 1



Snap-on



Slip-on

\$15-\$175

More beads = higher common mode suppression

Match to Mix

Wall Wart RFI Noise Reduction Kit

Wall Wart switching DC power supplies that plug into the AC power line plug and provide DC power to laptops, routers, battery chargers, cell phone chargers, etc are a known source of broadband RFI

A simple ferrite ring filter on the DC power line can help suppress the RFI noise affecting the device or keep the DC power cord from acting as an antenna and radiating RFI from the powered device.



RFI Filter on DC Cord



Economy 5 or 10 ring kit

RFI Newbies Special

Coax Noise Filter Comparison

OK



\$25

Snap On Choke
500-1000 Ω
1-2 "S" Units
SNO-1/2-5

Better



\$30

Ring Choke
1K-2K Ω
2-4 "S" Units
JC-1-1500

Best



\$70

Noise Filter
2K-6K Ω
3-6 "S" Units
CMNF-500-50

Criteria to Consider

- Adequate Choking Impedance (Z) > 500 Ω
- Effective Frequency Range where $Z > 500 \Omega$
- Sufficient Power Rating (PEP, Digital)
- Physical Size/Weight/Coax Diameter

FLEX Transceiver RFI Kits

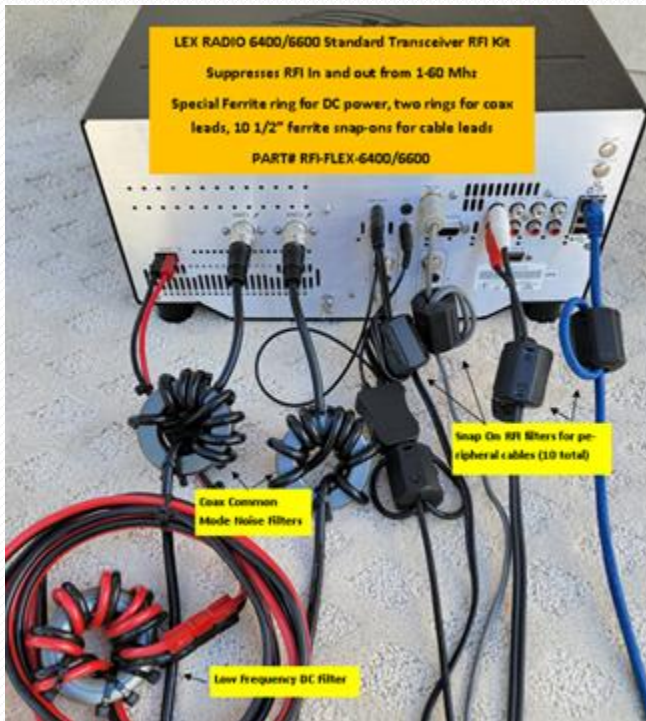

← 30 dB CMRR

+

Coax Noise Filter



=

46 dB CMRR →

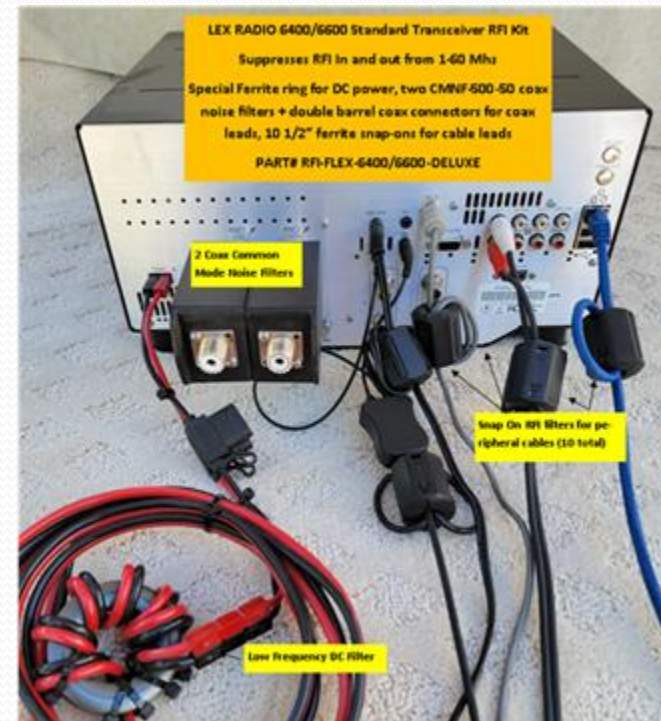

Tip #5. Install AC/DC Noise Filters

Lower Noise Floor = Higher SNR = More DX!

How to select and install filters for maximum effect

Goal is to reduce common mode RFI current from power supply



Q & A

- I will be available at the FLEX Radio booth or the HRO Booth during the Hamvention or you can call or contact me at Palomar-Engineers.com
- ENJOY THE HAMVENTION!

Flex Radio XCVR RFI Solutions

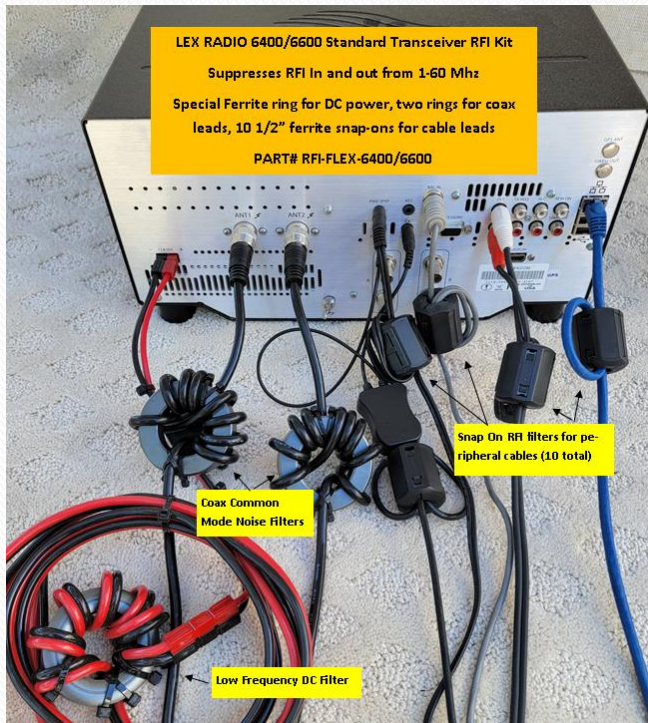

=

$46 \text{ dB CMRR} \rightarrow$

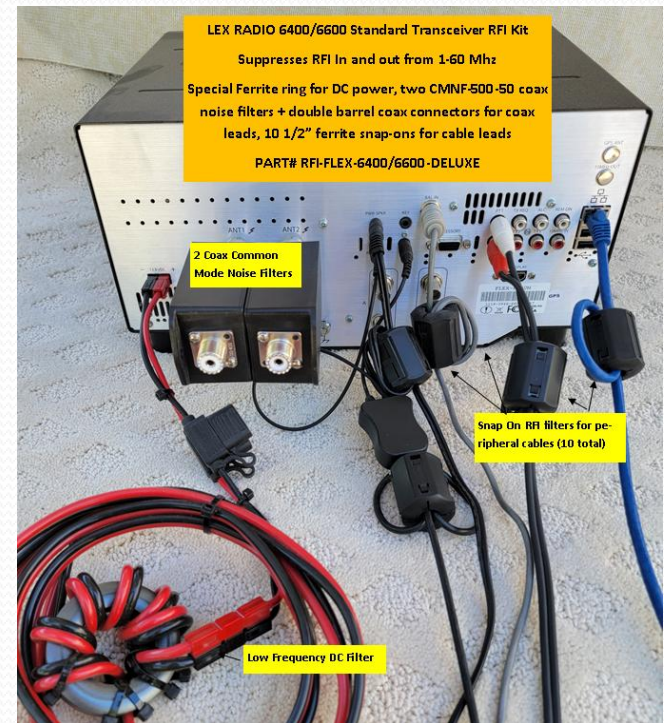

- Standard configuration (left) and Deluxe with coax noise filters (right)

FLEX Station RFI Kits

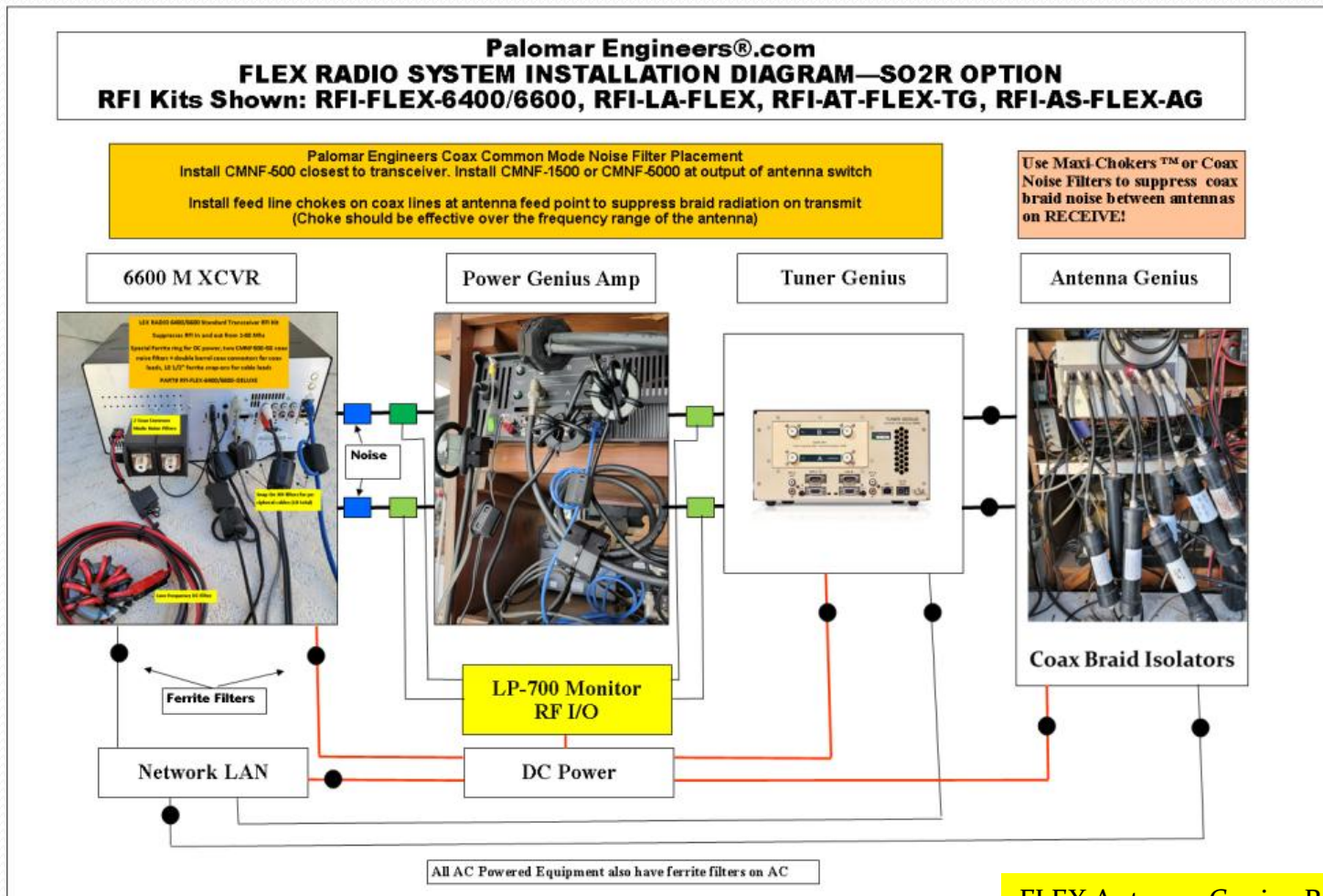

FLEX Antenna Genius RFI Solution

Flex Radio AG RFI Solutions



Ethernet, DC



RF Input



Coax Braid Isolators

- Always: Ethernet, DC, RF In, Optional: Coax Braid Isolation – Maxi-Choker/antenna

Stop Coax Braid Radiation on Transmit

Reduce RFI current to reduce RFI!

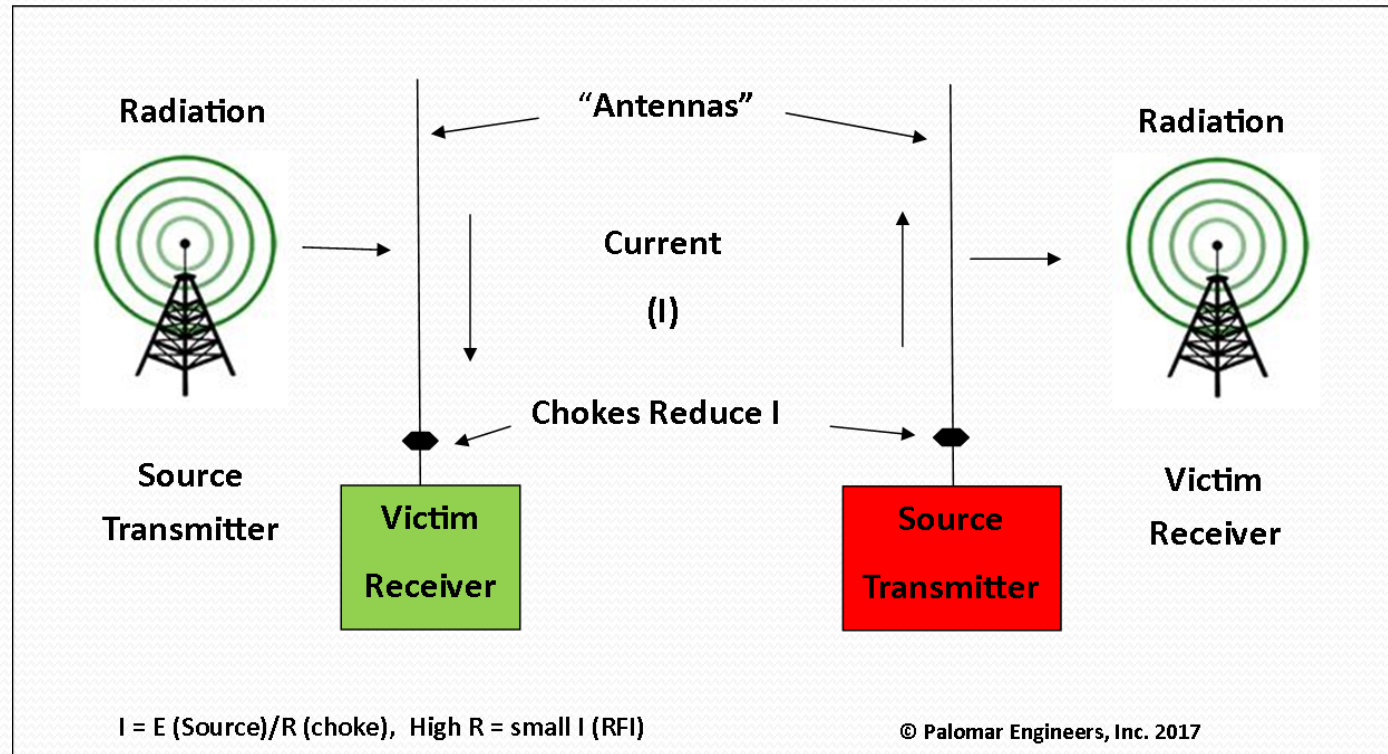

- Typical solutions: Resonant traps, ferrites, filters with high choking impedance



Ohms law is your answer